



What are Leaf Pots ?



The Farmers' Handbook - "Near The House 2", Chapter 9 - Leaf Pots

There are various methods to raise many different species of plant. Often, certain species cannot be transplanted as small seedlings, and they need to be sown direct in the garden or fields. When these species are sown, such as beans, pumpkins, gourds and cucumbers, lack of care for the small plants mean that many die due to pests, weeds, lack of water, etc., and are wasted. But by sowing in a *Leaf Pot* nursery, the plants can get the necessary care and attention when young, and be planted out when they are strong and healthy. This saves many seeds and plants from going to waste.

This method of using large leaves to make into pots, filling them with fertile soil and growing seedlings is called a *Leaf Pot* Nursery.



Watering leaf pots in a nursery

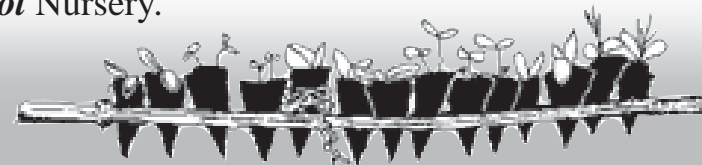

Why make Leaf Pots ?

- For growing seedlings which can't be transplanted from beds, such as some vegetables, fast growing trees or green manure seed plants, leaf pots can be used.
- Vegetables such as beans, pumpkin, cucumber, gourds, etc. cannot be transplanted bare-root, so these can be sown in leaf pots.
- Trees and green manure species, such as velvet bean, *Sesbania*, *Crotalaria* (such as sunhemp), lab lab bean, etc., which are to be used for seed production and so need more care and attention, can be started in leaf pots.
- When seedlings are growing in a leaf pot nursery, they can be given better care. This helps them to grow well, and also stops seed and seedlings being wasted.



This Booklet's Author :
Chris Evans, advisor,
Himalayan Permaculture Centre, Nepal
www.himalayanpermaculture.com



How to make Leaf Pots ?

Choose big, whole, unbroken leaves of the appropriate species. These leaves are rolled into a cone and stitched with bamboo pins. This will hold the soil well. After filling with fertile soil, the cones are sown with seed and covered with soil the same as if using polypots.

Materials Needed to make Leaf Pots

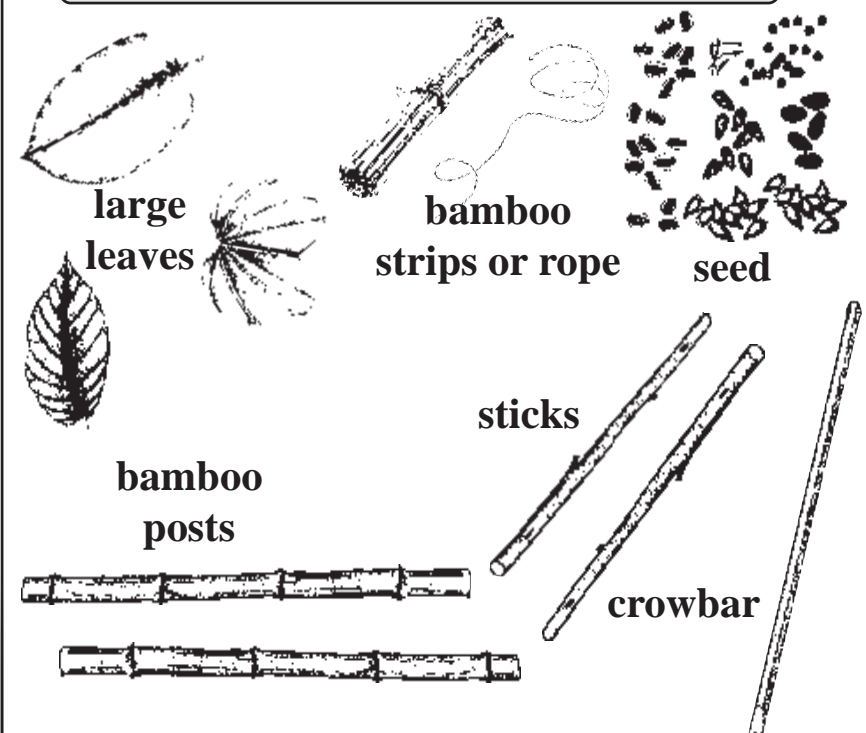

Making a Stand for the Leaf Pots

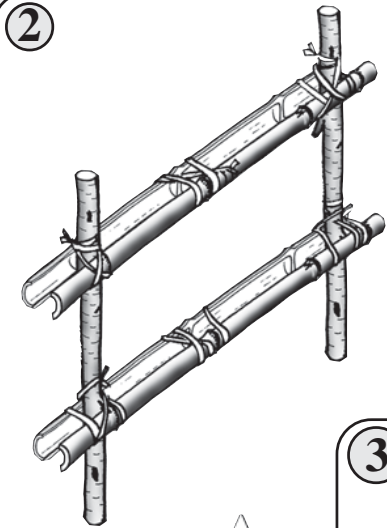

Split the bamboo and attach horizontally between the 2 uprights, to make a gap which the leaf pots can fit into.

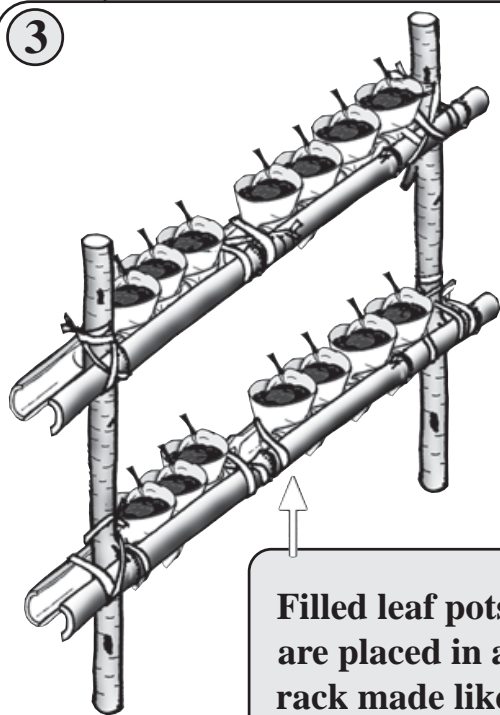
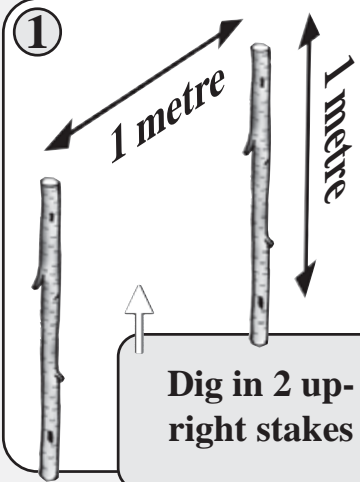

Filled leaf pots are placed in a rack made like this

Making the Leaf Pots

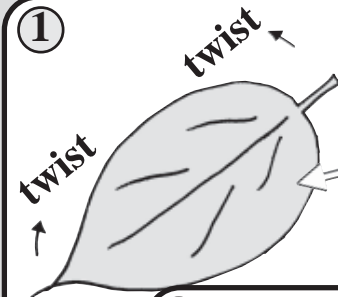

Use leaves to fit the size of seedling grown. Big leaves will make big pots for big seedlings, and small leaves for small pots with small seedlings

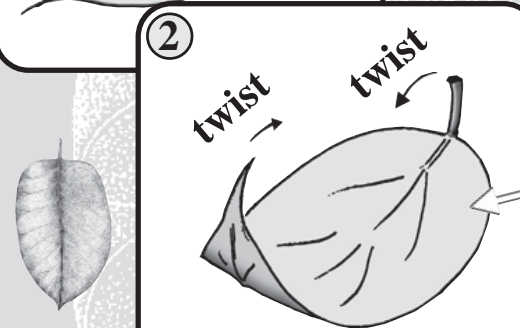

Take both ends of the leaf and start to twist

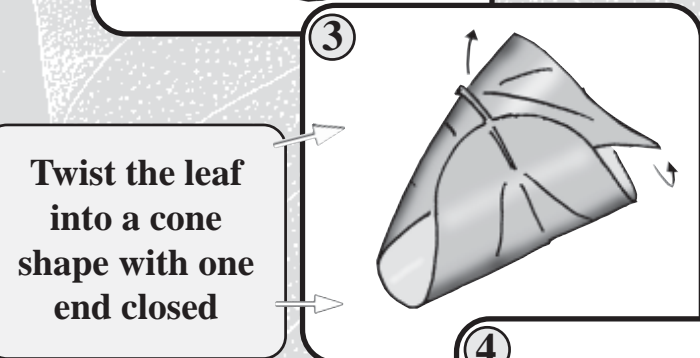

Twist the leaf into a cone shape with one end closed

Pin the leaf into a cone shape as shown here

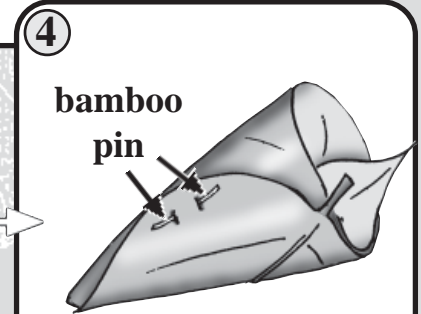

bamboo pin

Let's See

how to make Leaf Pots





Seed is sown in the pots and covered with a finger width of soil

Add water carefully



A seed starting to grow



These plants need watering daily

Maintenance

How to maintain Leaf Pots

Keeping the pots while seedlings grow

After sowing seed in the leaf pots, they need to be put in a safe place. The pots can be half buried in a nursery bed, or in a hot bed, as necessary. Another method for keeping leaf pots can be called a **vertical nursery**. This can only be used for cone-shaped leaf pots. A vertical nursery doesn't use up any land and can be made next to the house or on the edge of the courtyard. Seedlings will also be safe from chickens. See p. 4 for how to build the vertical nursery.



High output from a small area. Leaf pots under an air nursery, with a pit for liquid manure at ground level.

Because they are in the air, leaf pots in a vertical nursery can dry out quickly so need small amounts of water once or twice a day. If placed in the shade, they will need less water.

Planting the Leaf Pot

When the seedling has grown to the 4 leaf stage it can be planted out. At the place where it is to be planted, dig a small hole and fill with compost. Without taking the seedling out of the pot, plant both together in the hole. By doing this the roots of the seedling aren't disturbed. The leaf pot should be completely buried. After planting, add mulch and water well.



Seedlings being planted with their leaf pots

Farmers' Experience

Mrs Vishnumaya Shris

From Nepal, Surkhet district, Gumi - 3, Ratadada village, and a member of "Hariyali" women's group, Mrs Vishnumaya Shris has made her own leaf pots. Now let's hear what she says.



Mrs Vishnumaya Shris

“ If we plant various types of seed direct onto the land many can die, or not grow well. So we make leaf pots, filling them with soil and sowing them with seeds such as pumpkin, cucumber, beans, cow pea, bitter gourd, bottle gourd, etc., especially the climbing vegetables. We keep the pots in a vertical rack made from bamboo. We tie split bamboo in between 2 upright posts which leaves a gap perfect for holding the leaf pots. The pots need watering every day. Seedlings grow faster than if sown direct in the field, and are ready to plant out 2-3 weeks after sowing. We found that these plants suffer less from insect pests than others, perhaps because they're stronger. We share these skills in the group. I teach to some, and learn from others. ”





Read On !



Subjects Related to Leaf Pots

This book provides enough information to be able to make and grow plants in your own leaf pots. However, this information is also linked to other methods. For extra benefits let's read, learn and practice from other related chapters.

Leaf Pot chapter



Kitchen Garden chapter

Leaf pots are very useful in successful vegetable gardening. Information about this and other easy methods for home-producing healthy vegetable at low cost is given in this chapter



Hot Bed chapter

This chapter describes how to use leaf pot seedlings along with other varieties in a hot bed to grow off season vegetables



Mixed Vegetable Gardening chapter

With less weeding, watering and other work, and harvesting various types of vegetables from 3 weeks after planting, lasting up to 6 months. Information on this easy technique is given in this chapter